

TAC Summer School 2023
University of King's College, Halifax, Nova Scotia, Canada
Friday 4 August Evening Social

Programme devised by Melissa Whitson

The Waratah Weaver	(J4x32)	4C	(4C set)	RSCDS: Second Graded Book #4
The Braes of Tulliemet	(S8x32)	3C	(4C set)	RSCDS: Book 7 #12 *
Ha! Ha! The Woonin' O' It	(R8x32)	2C	(4C set)	RSCDS: MMM 1 #29
Caldercruix	(J8x32)	3C	(4C set)	Drewry, The Bankhead Book 3 #8 *
Lord Elgin's Reel	(S8x32)	3C	(4C set)	RSCDS: Book 26 #5
Mrs Stewart of Fasnacloich	(R8x32)	3C	(4C set)	RSCDS: Leaflet Dances #21 *

INTERMISSION

The Express	(J8x40)	3C	(4C set)	RSCDS: Book 20 #11 *
Mrs Milne of Kinneff	(S4x32)	4C	(sq set)	RSCDS: Leaflet Dances #20
The Comeback Jig	(J8x32)	3C	(4C set)	Elaine Brunken, Moments in Time #3
Lady Susan Stewart's Reel	(R8x32)	3C	(4C set)	RSCDS: Book 5 #9

Dance list available at <https://my.strathspey.org/dd/list/38008/>



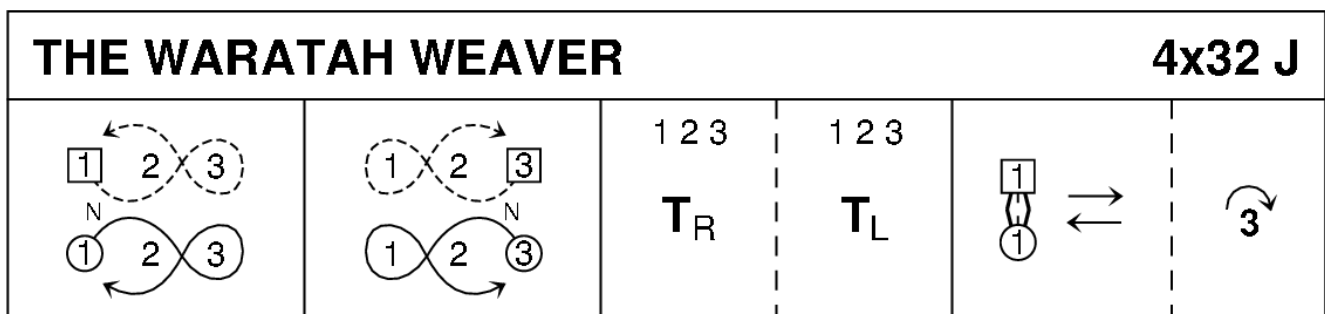

THE WARATAH WEAVER (J4x32) 4C (4C set) See, RSCDS: Second Graded Book #4
 1- 8 1s dance Figs of 8 on own sides (dancing in and down to start)
 9-16 3s dance Figs of 8 on own sides (dancing in and up to start)
 17-24 1s+2s+3s turn RH, turn LH
 25-32 1s slip step down for 4 steps and up to top; 1s cast to bottom as 2s+3s+4s step up



Elma See, RSCDS Graded Book 2.4

4C/4C longwise set.



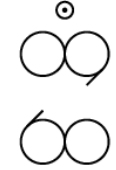

THE BRAES OF TULLIEMET * (S8x32) 3C (4C set) Castle Menzies, RSCDS: Book 7 #12
 1- 8 1s set and cast 1 place (2s step up); 1s cross RH and cast down 1 place (3s step up)
 9-16 3s+1s dance 4H round to left; 1s lead up to top
 and cast on opposite sides to face 1st corners
 17-24 1s set to and turn 1st corner; set to and turn 2nd corner
 25-32 1s dance 6-bar LSh reels of 3 on opposite sides (LSh to 1st corners);
 1s cross RH to 2nd place on own sides

THE BRAES OF TULLIEMET			8x32 S
S  X_R 	3 1x   	S T_B	 X_R

RSCDS Book 7.12

3C/4C longwise set.

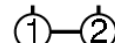
HA! HA! THE WOONIN' O' IT (R8x32) 2C (4C set) RSCDS: MMM 1 #29
 1- 8 1L+2L advance towards partners and set, retire and set
 9-16 1M+2M repeat bars 1- 8
 17-24 1s lead down and back
 25-32 1s+2s dance Poussette

HA! HA! THE WOONIN' O' IT			8x32 R
 1 2 S  1 2 S	R 		1 2 P

RSCDS MMM (29)

2C/4C longwise set.

CALDERCRUIX * (J8x32) 3C (4C set) John Drewry, 1993 Bankhead Book 3 #8
 1- 8 1s set and cross down RH to dance RSh round 1st corners; 2s step up on 3-4;
 1s ½ turn RH in centre
 9-16 1s dance the Snake Pass: 1s dance LH across (1M with 2s and 1L with 3s),
 1M, followed by 2s, also 1L, by 3s, cross diagonally passing RSh to change ends
 and loop round to right
 17-24 3s+1s+2s circle 6H round to left, then cast left to chase back to own sides
 25-32 3s+1s+2s ½ turn LH and set (retaining hands);
 all cast to chase clockwise ½ way to end on own sides

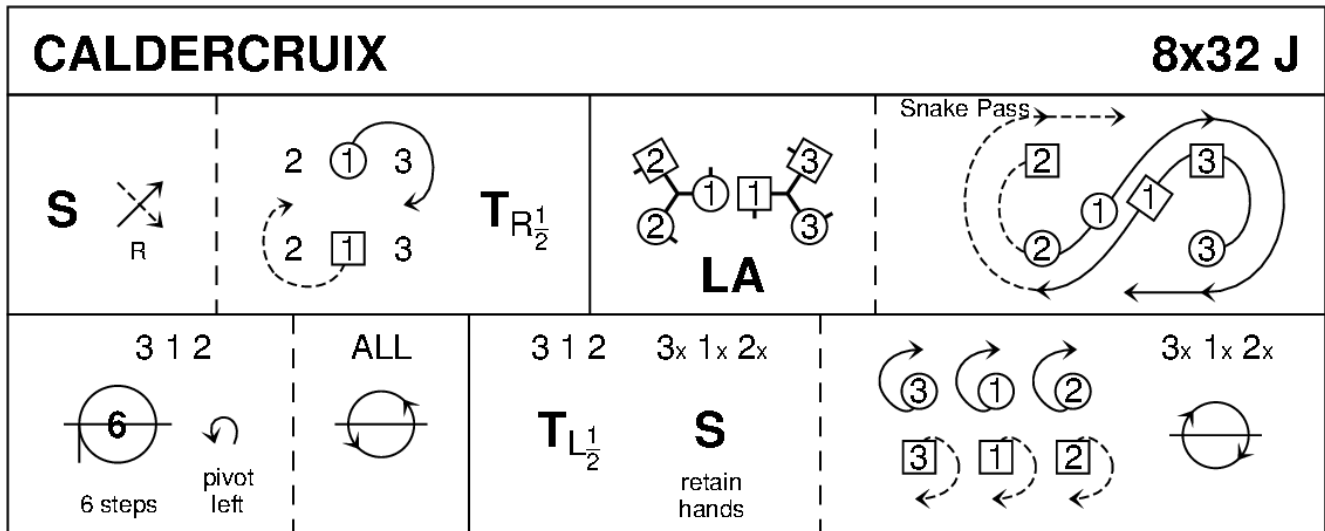

John Drewry, 1993, Bankhead Book 3

3C/4C longwise set.

LORD ELGIN'S REEL (S8x32) 3C (4C set) RSCDS: Book 26 #5
 1- 8 1M+2L set and turn 2H; 1L+2M set and turn 2H
 9-16 1s cross down RH below 2s, dance behind and around 3s, lead up to top,
 cross RH and cast to face 1st corners; 2s step up on 15-16
 17-24 1s turn 1st corners RH, pass RSh to turn 2nd corner LH and pass LSh
 to end in lines across: 1L between 2s and 1M between 3s
 25-32 Lines advance and retire 1 step twice; 1s turn 2H 1¼ times to own sides

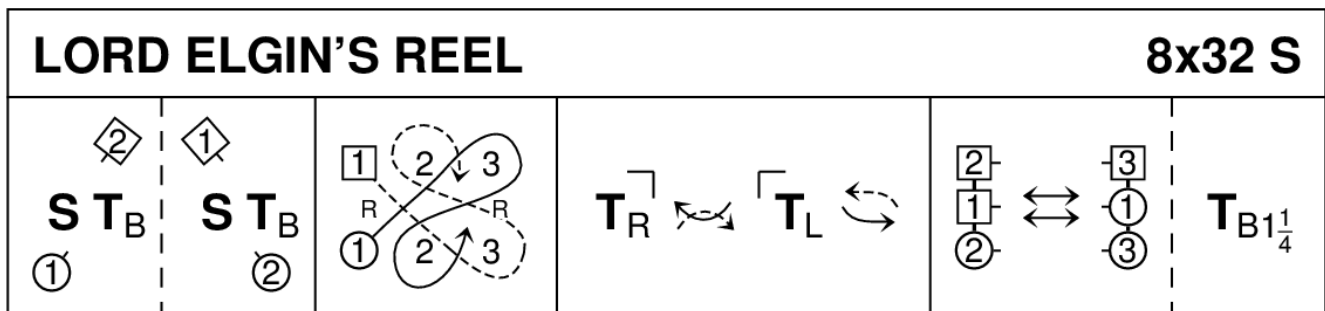

RSCDS Book 26.5

3C/4C longwise set.

MRS STEWART OF FASNACLOICH * (R8x32) 3C (4C set) RSCDS: Leaflet Dances #21

- 1- 8 1s and 2s petronella turn into centre and set, 3/4 turn partners RH and 1s+2s dance 1/2 RH across (1s end in 2nd place own sides)
- 9-16 1s cross down RH through 3rd place to dance reel of 3 with 2s+3s on opposite sides (RSh on Ladies' side and LSh on Men's side); 1s end facing 2nd corners
- 17-24 1s dance 1/2 diagonal reel of 4 with 2nd corners, turn LH to dance 1/2 LSh reel of 4 with 1st corners; 1s pass LSh to end BtoB in centre (1M facing up, 1L down)
- 25-32 1s circle 3H round to left (Man with 3s and Lady with 2s); 1s drop LH and open up to circle 6H round to left 1/2 way; all set

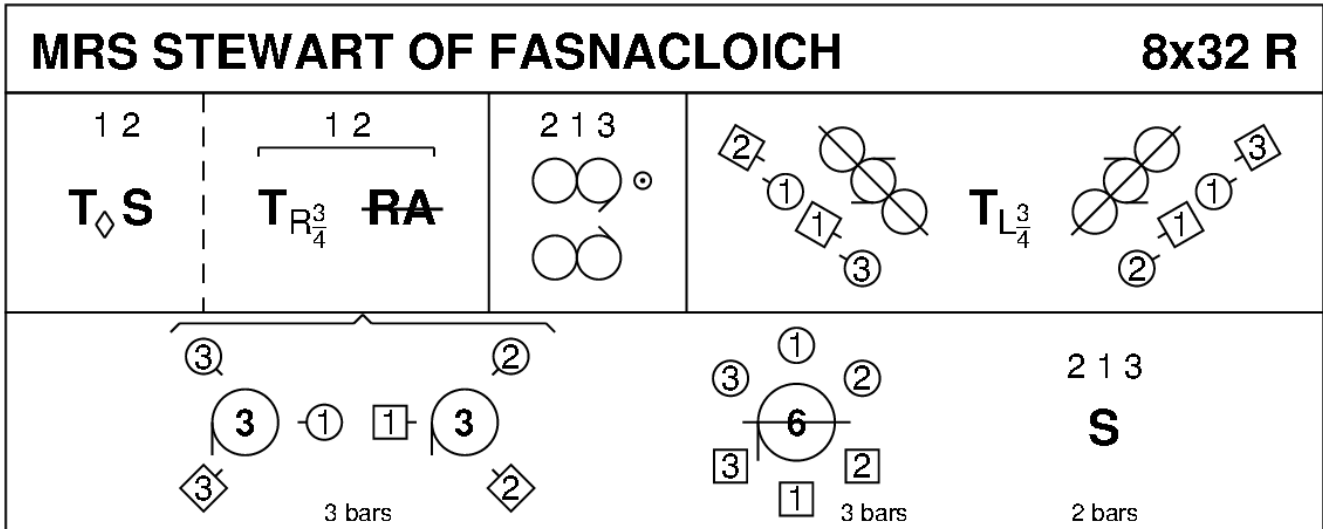

RSCDS, 1973, RSCDS Leaflet 18

3C/4C longwise set.

THE EXPRESS * (J8x40) 3C (4C set) RSCDS: Book 20 #11

- 1- 8 1s cross down through 2nd place to dance mirror reels of 3 on opposite sides
- 9-16 1s cross down through 2nd place to dance mirror reels on own sides
- 17-24 1s lead down the middle and back
- 25-32 1s+2s dance Allemande; 1s end in centre in double triangle positions
- 33-40 1s dance Double Triangles

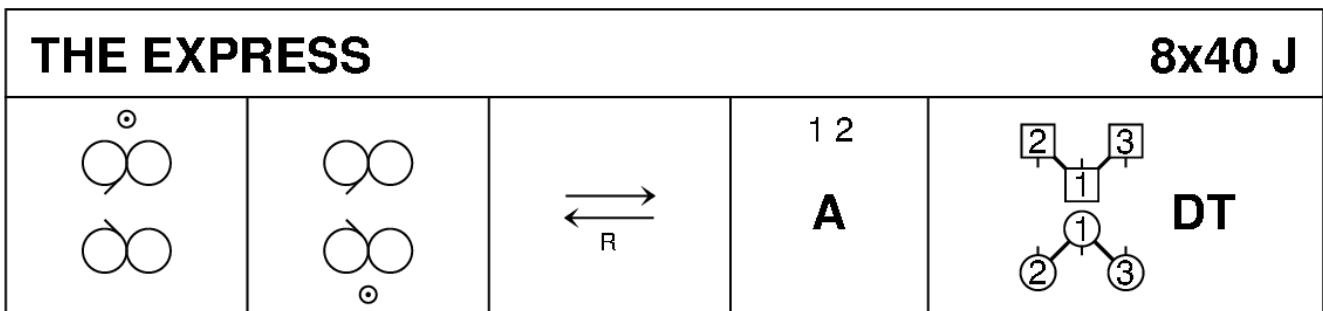

Button and Whittaker, 1814, RSCDS Book 20.11

3C/4C longwise set.

MRS MILNE OF KINNEFF (S4x32) Sq.Set Alan MacPherson, RSCDS: Leaflet Dances #20

- 1- 8 1s and 3s join hands with partner and advance for 2 steps,
turn opposite dancer RH once round, retaining opposite dancer's hand
to dance RH across with 2s/4s
- 9-16 Dancing couples (1M+3L and 1L+3M) face side couples
to dance parallel reels of 4 across the dance
- 17-24 Dancing couples (1M+3L and 1L+3M) set to side couples
then dancing couples dance out between side couples and cast to original places
WHILE side couples separate and dance into centre to meet partners,
take nearer hands and dance out to original places; all turn partners 2H
- 25-32 All circle 8H ½ way round to left; ¾ turn partners RH into prom hold (Ladies on inside)
and promenade 1 place clockwise

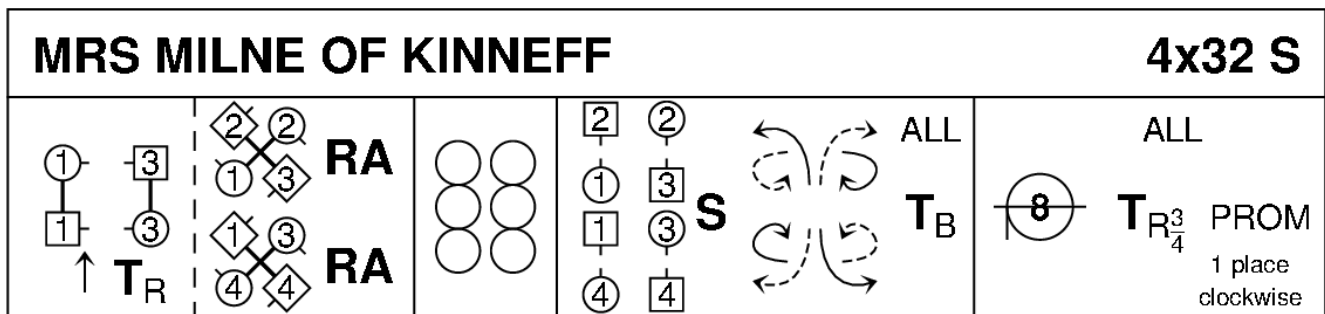

Alan Macpherson, RSCDS Leaflet 32

4C/4C square set.

THE COMEBACK JIG (J8x32) 3C (4C set) Elaine Brunken, Moments in Time #3

- 1- 8 1s dance ½ Fig of 8 round 2s, then ½ Fig of 8 round 3s;
1s end in 2nd place own sides; 2s step up 7-8
- 9-16 2s+1s+3s dance RSh round partners, dance out to own sides
and chase clockwise ½ way round
- 17-24 1s dance RH across (1L+2s in 3rd place, 1M+3s in 1st place);
1s change ends to dance LH across
- 25-32 2s+1s+3s chase anticlockwise ½ way round;
all dance round partners LSh to end on own sides

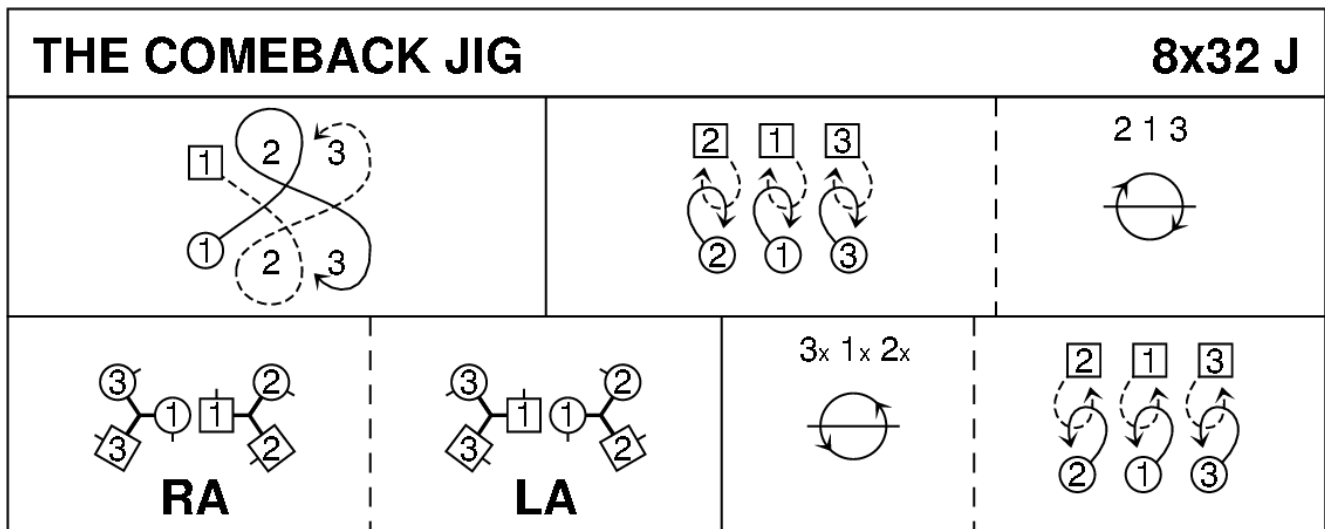

Elaine Brunken, 2012, Moments in Time

3C/4C longwise set.

LADY SUSAN STEWART'S REEL (R8x32) 3C (4C set) RSCDS: Book 5 #9

1- 8 1s set, cast below 3s, lead up to top and cast to face 1st corners; 2s step up on 7-8

9-16 1s set to corners and partner and end facing 1st corners

17-24 1s turn 1st corners RH, partner LH, 2nd corners RH and partner LH
to end own sides, facing down

25-32 1s dance down between 3s, cast up on own sides, dance up between 2s
and cast to 2nd place own sides

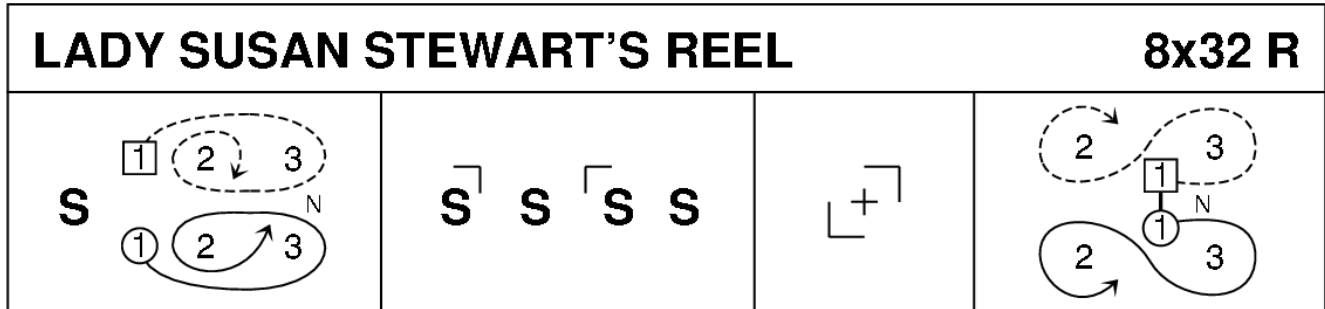

Caledonian Country Dances, c.1754, RSCDS Book 5.9

3C/4C longwise set.